

## PACKAGING SOLUTION FOR **ALL AND EVERY** APPLICATION

### OUR MANUFACTURE PROGRAM:

**TOBOGAN** Vertical packaging machines

**BOX** Cartoning machines

**GOLEM** Bulk bags packaging machines

**VOLCANO** Multilane stickpack packaging machines

**CUBE** Brickpack packaging lines

**CASE** Group packaging casepackers

**ROBOTIC** Manipulation lines

Wide range of accessories

PACKAGING MACHINERY DESIGN, DEVELOPMENT AND MANUFACTURE.  
TAILOR-MADE COMPLETE PACKAGING LINES.

## **TOBOGAN 250S** **VERTICAL PACKAGING MACHINE**

(with multi-head weighers and other accessories)

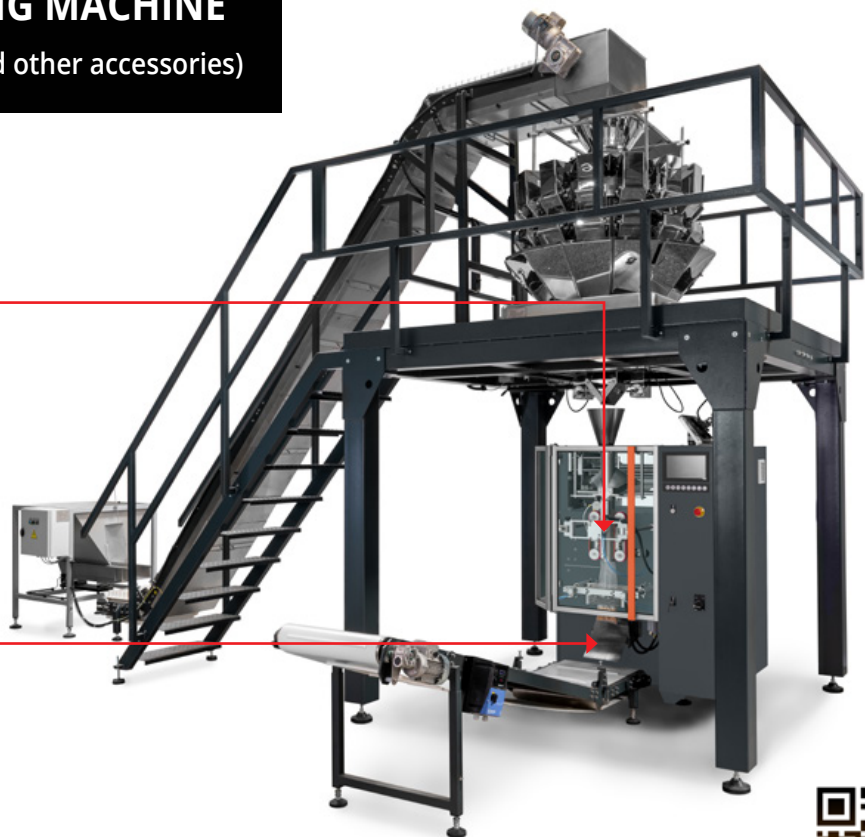

**Automatic production of single bags from heat or impulse sealable packing film**

**Output: up to 100 cycles/min. (single lane)\***

Device dimensions: h 1600 mm w/o dosing unit | w 1220 mm | d 2060 mm

**Bag dimensions: w 32-250 mm | l 60-350 mm**

Packed products: loose (powder, granules) | small pieces | liquids/paste



\* depending on packed amount, type of product and size of package

## BOX ROBO GROUP ROBOTIC CARTONING DEVICE

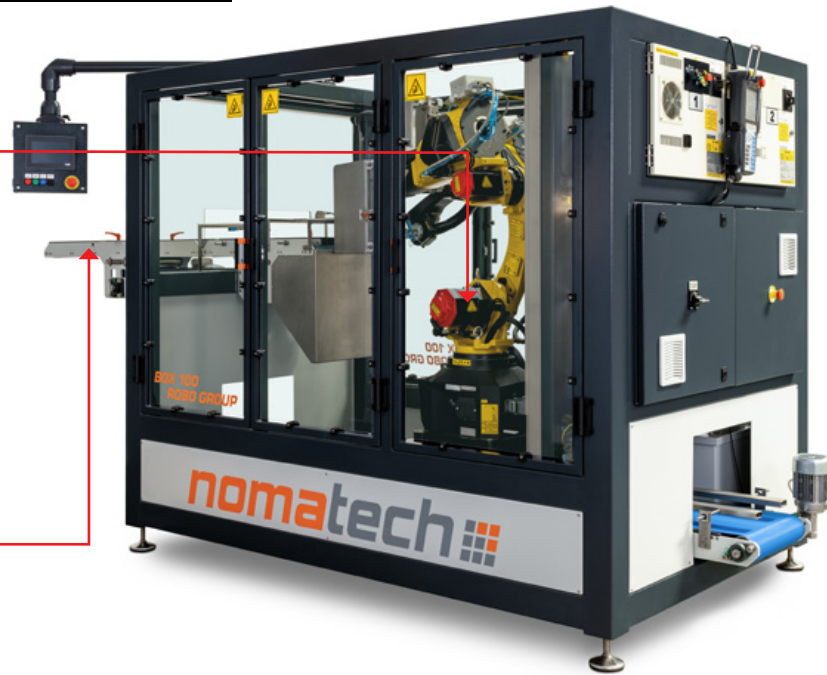

### Robotic group packing into carton trays/boxes

Output: up to 6000 bags/hr.\*

Device dimensions: h 1930 mm | d 3935 mm | w 1450 mm

Box dimensions: w 90-180 mm | l 200-400 mm | h 150-200 mm | individual request

Bag dimensions: max. 150x190 mm

Packed products: prepacked bags



## BOX 60V VERTICAL CARTONING DEVICE

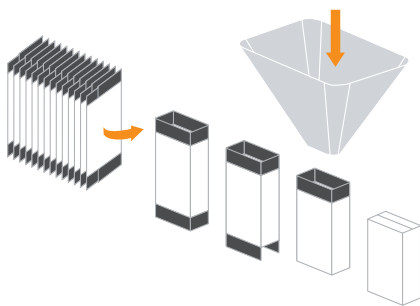

### Automatic inserting of loose or prepacked goods into carton boxes vertically

Output: up to 3000 packages/hr.\*

Device dimensions: h 2000 mm | w 2350 mm | d 2700 incl. feeding conveyor

Box dimensions: w 35-180 mm | l 35-180 mm | h 11-80 mm

Packed products: pieces | loose | filled bags

Includes: carton erector | flap folding | carton glueing



## BOX 60H HORIZONTAL CARTONING DEVICE

(with a horizontal flowpack packaging machine)

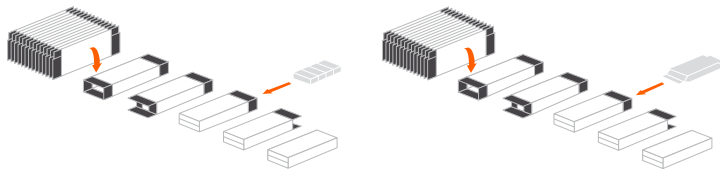
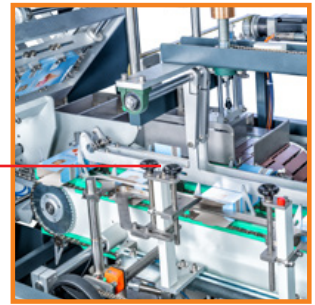

Automatic inserting of prepacked goods into carton boxes horizontally

Output: up to 3000 packages/hr.\*

Device dimensions: h 1620 mm | w 4000 mm | d 1400 mm incl. feeding conveyor

Box dimensions: w 20-250 mm | l 120-300 mm | h 20-100 mm

Packed products: prepacked bags

Includes: carton erector | flap folding | carton glueing



## BOX 60H mini HORIZONTAL CARTONING DEVICE

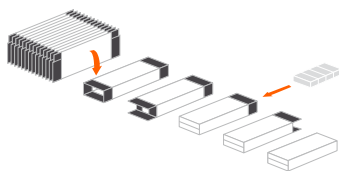
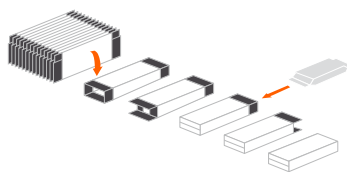

Automatic group packing into carton boxes

Output: up to 3600 package/hr.\*

Device dimensions: h 1940 mm | d 3810 mm | w 2100 mm

Box dimensions: w 20-80 mm | l 70-180 mm | h 13-75 mm

Packed products: small pieces of regular shape

Includes: carton erector | carton sealer



\* depending on packed amount, type of product and size of package

# GOLEM FLEXI BAGGING LINE

(with an auger doser)

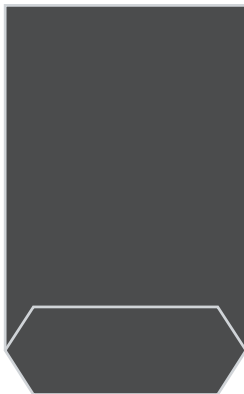
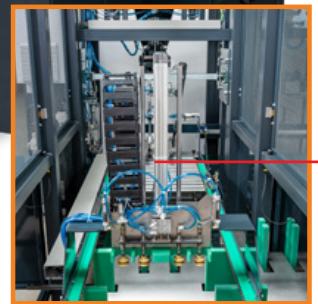
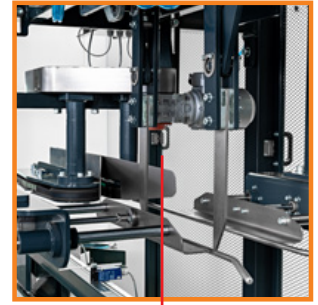
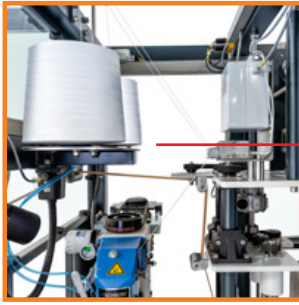

## Automatic filling of premade large volume bags

Output: up to 600 packages/hr.\*

Device dimensions: h 2190 mm w/o dosing unit | w 4970 mm | d 3930 mm

Bag volume: up to 75 l | individual request

Bag closing: sealing | sewing | glueing | stretch band

Packed products: loose (powder, granules) | small pieces



**nomatech**  
YOUR PACKAGING MACHINES

info@nomatech.net | www.nomatech.net | +420 317 843 235  
Vlasáková 1635 | 258 01 Vlašim | Czech Republic  
Tradition since 1965

