

DOSING DEVICES

nomatech 
YOUR PACKAGING MACHINES

AUGER DOSING DEVICES



	RACKET S	RACKET S MICRO
Output:	up to 190 l/min.*	up to 22 l/min.*
Dose size:	max. 5000 g	max. 300 g
Suitable for:	powders and dusty products	
Accessories:	tube closing flap mixing system	
Material:	contact parts in stainless steel	
Advantages:	augers are designed according to product type and quantity	
	easy cleaning	faster for small doses
	openable hopper	accuracy
	possibility to divide hopper	
	fast auger change	
	dust extraction	

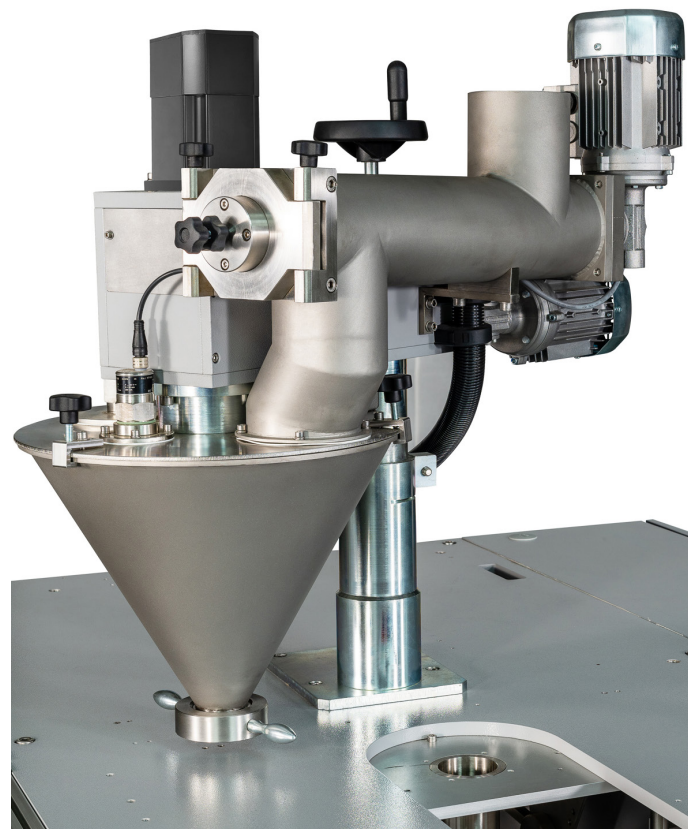
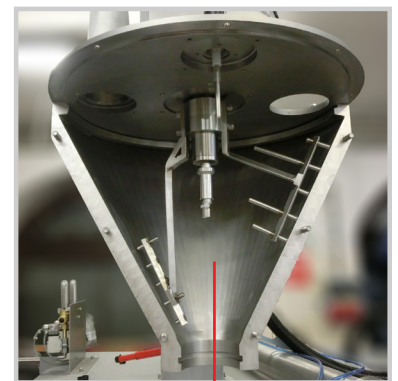

*depending on dosed amount, type of product and size of package

MULTIHEAD WEIGHERS



	CHW210	CHW214
Number of heads:	10	14
Output:	up to 70 doses/min.*	up to 120 doses/min.*
Dose size:	10-1000 g	10-2000 g
Accuracy:	0,2-2 g	0,1-2 g
Suitable for:	loose granulates powders pieces sticky products	
Accessories:	timing hopper rotating top cone	
Material:	stainless steel	
Advantages:	high accuracy and speed IP65 waterproof and dustproof design easy cleaning and maintenance	



VOLUMETRIC SLIDE DOSING DEVICES



	RACKET OS
Number of rows:	1-10
Output:	individual*
Dose size:	individual request
Suitable for:	loose products
Accessories:	dosing desk for another volume product level monitoring in the hopper
Material:	contact parts in stainless steel
Advantages:	easy cleaning conversion to another volume

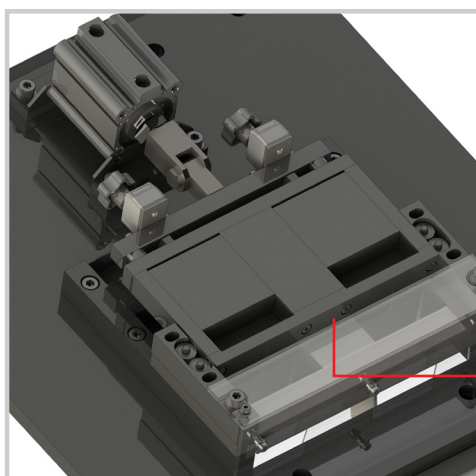

VOLUMETRIC FRICTIONAL DOSING DEVICES



	RACKET OT	RACKET OT EXTRA
Output:	up to 140 doses/min.*	up to 80 doses/min.*
Dose size:	max. 2 l	max. 10 l
Accuracy:	1-5 %	
Suitable for:	loose products	
Accessories:	product level monitoring in the hopper	
Material:	contact parts in stainless steel, plastic	
Advantages:	easy cleaning exchange of measuring cups for another volume	

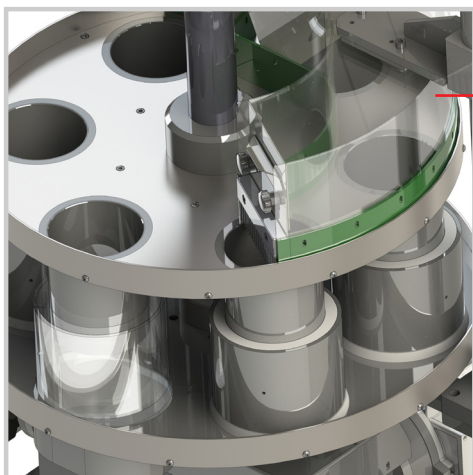
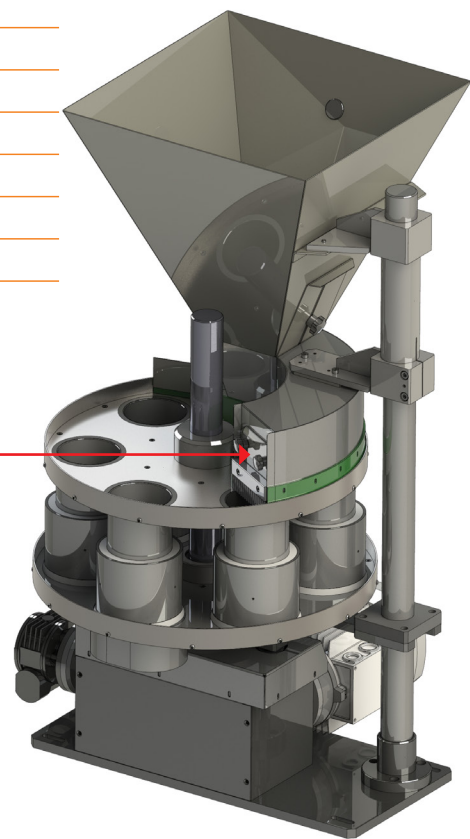

VOLUMETRIC FLAP DOSING DEVICES



	RACKET OK	RACKET OK EXTRA
Output:	up to 120 doses/min.*	up to 80 doses/min.*
Dose size:	max. 2 l	max. 10 l
Accuracy:	1-5 %	
Suitable for:	loose products	
Accessories:	product level monitoring in the hopper	
Material:	contact parts in stainless steel	
Advantages:	easy cleaning exchange of measuring cups for another volume	

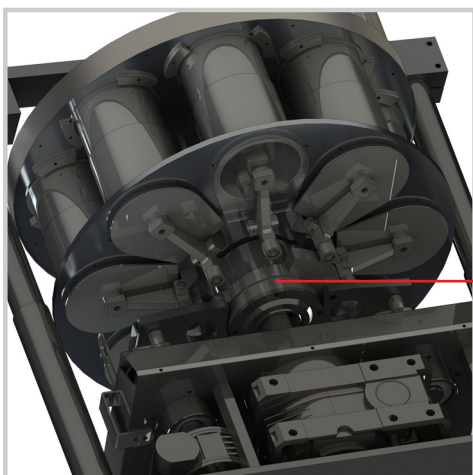
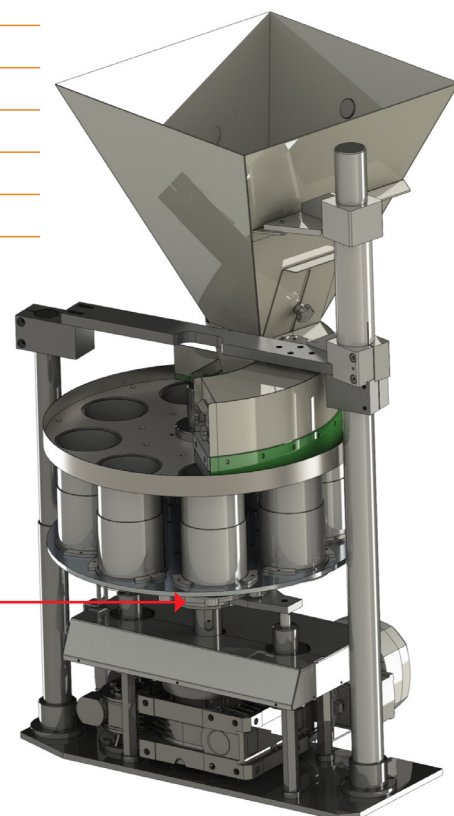

*depending on dosed amount, type of product and size of package

LINEAR | BELT WEIGHERS



	RACKET LW4	RACKET LW2
Number of rows:	4	2
Output:	up to 50 doses/min.*	up to 30 doses/min.*
Dose size:	20-2000 g	20-3000 g
Accuracy:	0,2-2 g	0,2-2 g
Suitable for:	loose granulates small piece products	
Material:	contact parts in stainless steel	
Advantages:	easy cleaning and maintenance dustproof design mixing 2 products in one batch	

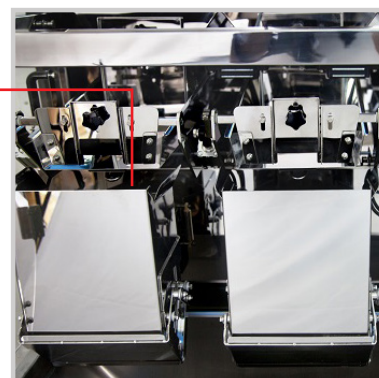
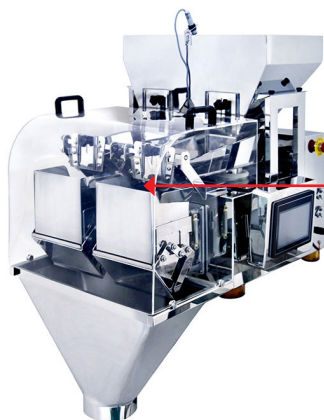

	RACKET DVP
Output:	up to 50 doses/min.*
Dose size:	500-10000 g
Accuracy:	0,2-5 g
Suitable for:	loose granulates small piece products
Material:	steel
Advantages:	precise weighing of large volumes



*depending on dosed amount, type of product and size of package

OUR MANUFACTURE PROGRAM:

TOBOGAN Vertical packaging machines
VOLCANO Multilane stickpack packaging machines
GOLEM Bulk bags packaging machines
BOX Cartoning machines

CUBE Brickpack packaging lines
CASE Group packaging casepackers
ROBO Manipulation lines, palletization
LUNA Filling and mixing lines
 Wide range of accessories and more.



NOMATECH s.r.o.
 info@nomatech.net | www.nomatech.net | +420 317 843 235
 Vlasáková 1635 | 258 01 Vlašim | Czech Republic
 Tradition since 1965



Co-funded by
 the European Union

nomatech
 YOUR PACKAGING MACHINES