

# COMPLEX MIXING, DOSING AND FILLING LINES

## **nomatech**

YOUR PACKAGING MACHINES

### LUNA-T MIX | LUNA-L

#### MULTICOMPONENT MIXING AND FILLING INTO TUBES INCLUDING CLOSING

The shown line for mixing 10 components includes: vertical packaging machine TOBOGAN 250S (flat bags) | multihead weighers CHW210/214 | bucket conveyor | filling station LUNA-T (tubes) | lid applicator LUNA-L | X-ray control | checkweighers | marking device | rotating table OS | complete stock management | conveyor system

Output: up to 45 packages/min. (10 components) | depending on number of filled components\*

Device dimensions: individual according to a specific tailor-made solution

Package dimensions: individual request | multiple formats

Package material: paper | plastic | glass

Closing: lid - lid applicator LUNA-L | BLEMA | STILLER

Packed products: loose (powders, granules) | small pieces



Rotating table OS

Vertical packaging machine TOBOGAN 250S

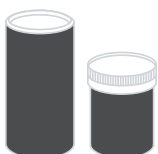
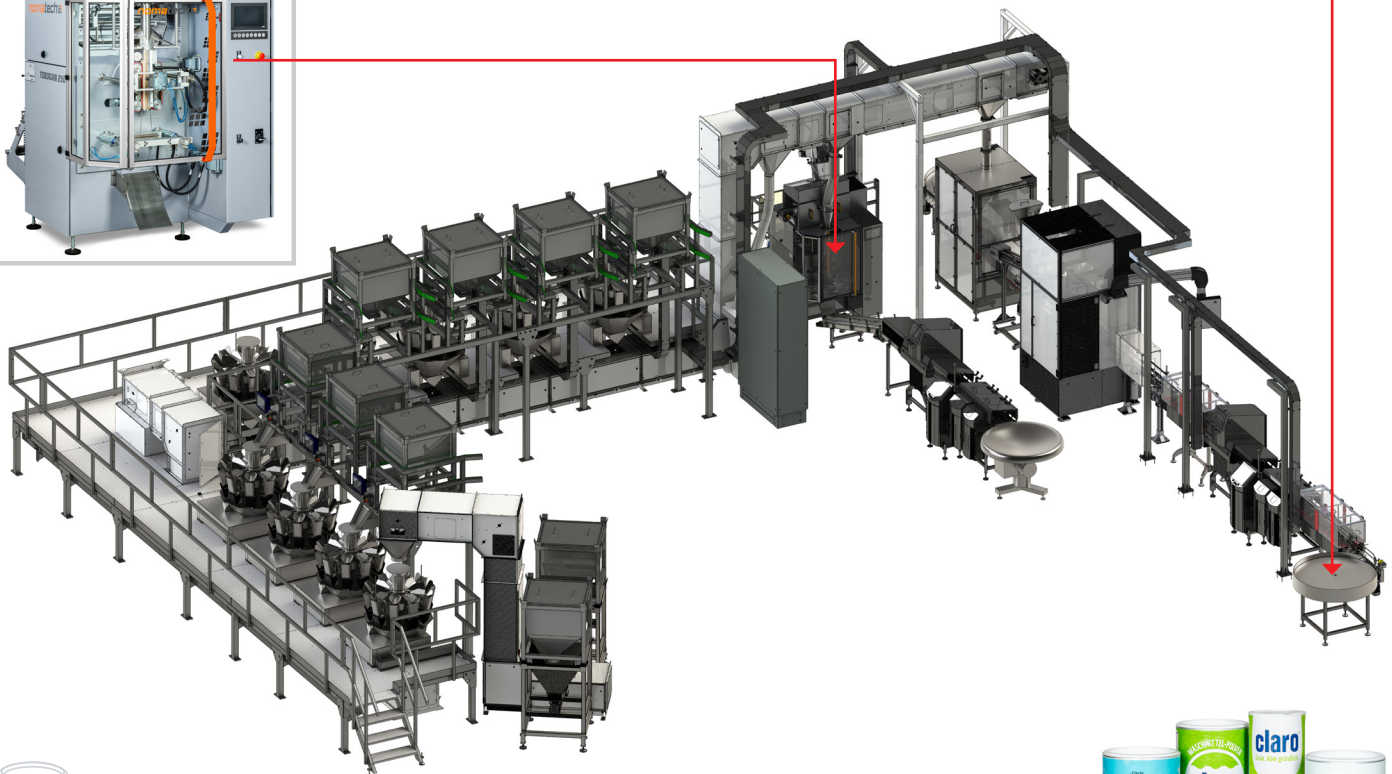

\*depending on the filled amount, product type and package dimensions  
Note: All lines are always designed individually depending on the customer's requirements.

## LUNA-C MIX | LUNA-L

### MULTICOMPONENT MIXING AND FILLING INTO CUPS INCLUDING CLOSING

The shown line for mixing 6 components includes: multihead weighers CHW210 | auger doser RACKET S | slide doser RACKET OS | complete stock management | supply of individual components | robotic spice bag insertion | conveyor system | filling station LUNA-C MIX (cups) | lid applicator LUNA-L | checkweighers with metal detector | rotating table OS | marking device

Output: up to 60 packages/min. (6 components) | depending on number of filled components\*

Device dimensions: individual according to a specific tailor-made solution

Package dimensions: individual request | multiple formats

Package material: paper | plastic

Closing: lids – lid applicator LUNA-L | BLEMA | STILLER

Packaged products: loose (powders, granules) | small pieces | pastes, liquids



Robotic arm



Auger dosing unit RA

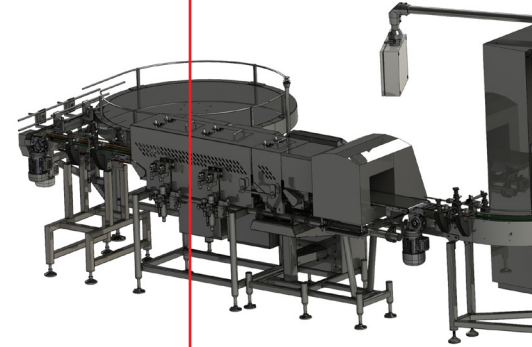

## LUNA-T MIX | LUNA-C MIX | LUNA-L

### MULTICOMPONENT MIXING AND FILLING INTO TUBES AND CUPS INCLUDING CLOSING

The shown line for mixing 12-20 components includes: multihead weighers YAMATO | auger doser RACKET S | linear weighers RACKET LW4 | filling station LUNA-T (tubes) | filling station LUNA-C (cups) | lid applicator LUNA-L | X-ray control | checkweighers | rotating table OS | marking device | complete stock management | conveyor system

Output: up to 45 packages/min. (12-20 components) | depending on number of filled components\*

Device dimensions: individual according to a specific tailor-made solution

Package dimensions: individual request | multiple formats

Package material: paper | plastic | glass

Closing: lids – lid applicator LUNA-L | BLEMA | STILLER

Packaged products: loose (powders, granules) | small pieces



Multihead weighers YAMATO

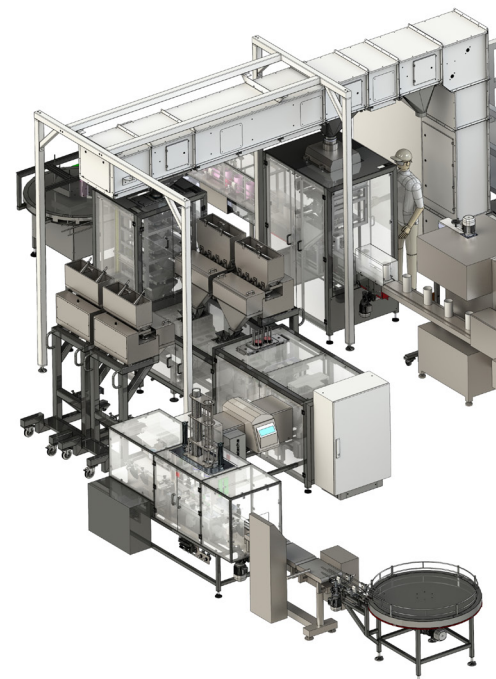

\*depending on the filled amount, product type and package dimensions  
Note: All lines are always designed individually depending on the customer's requirements.



PACKET S

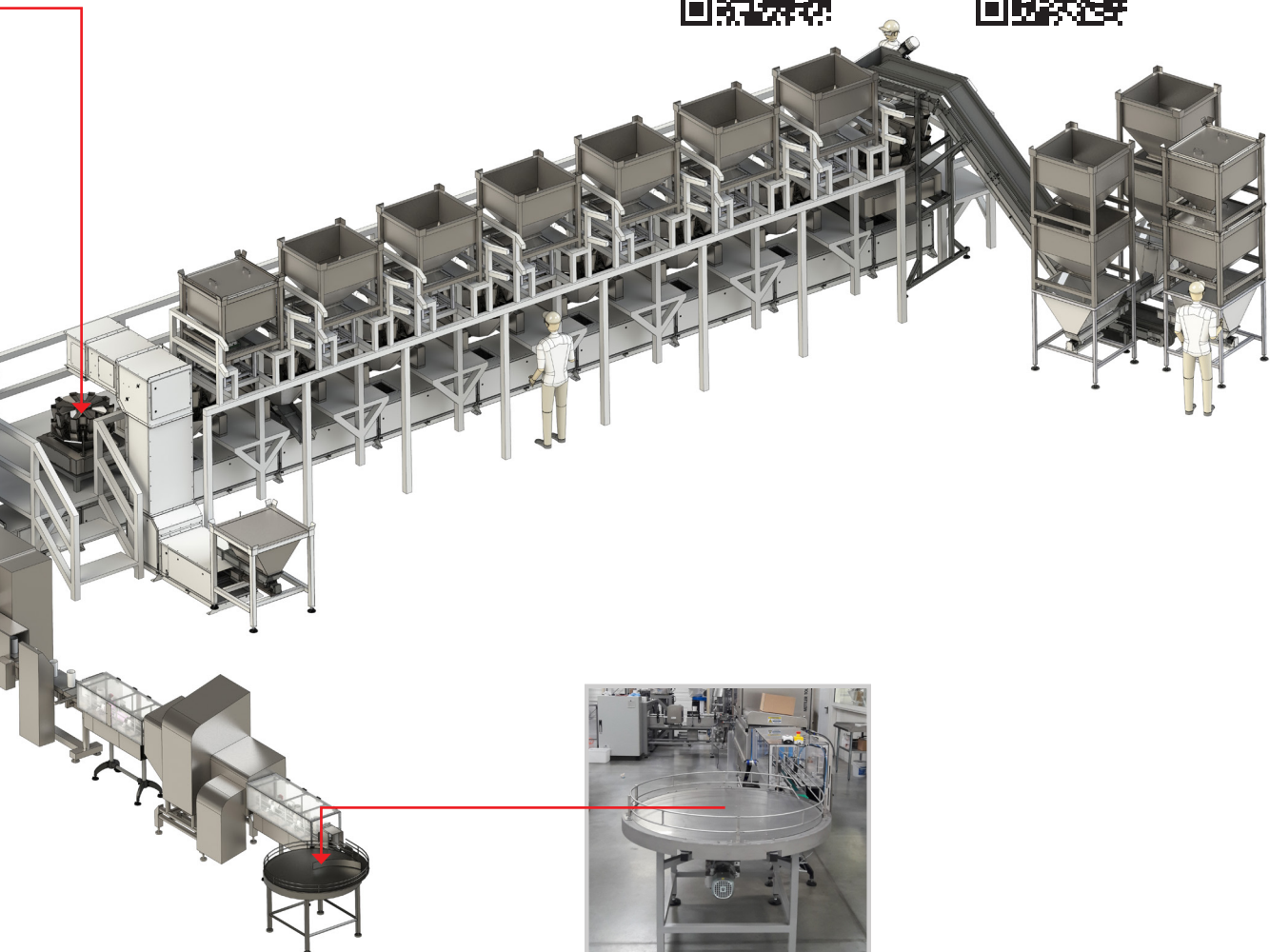
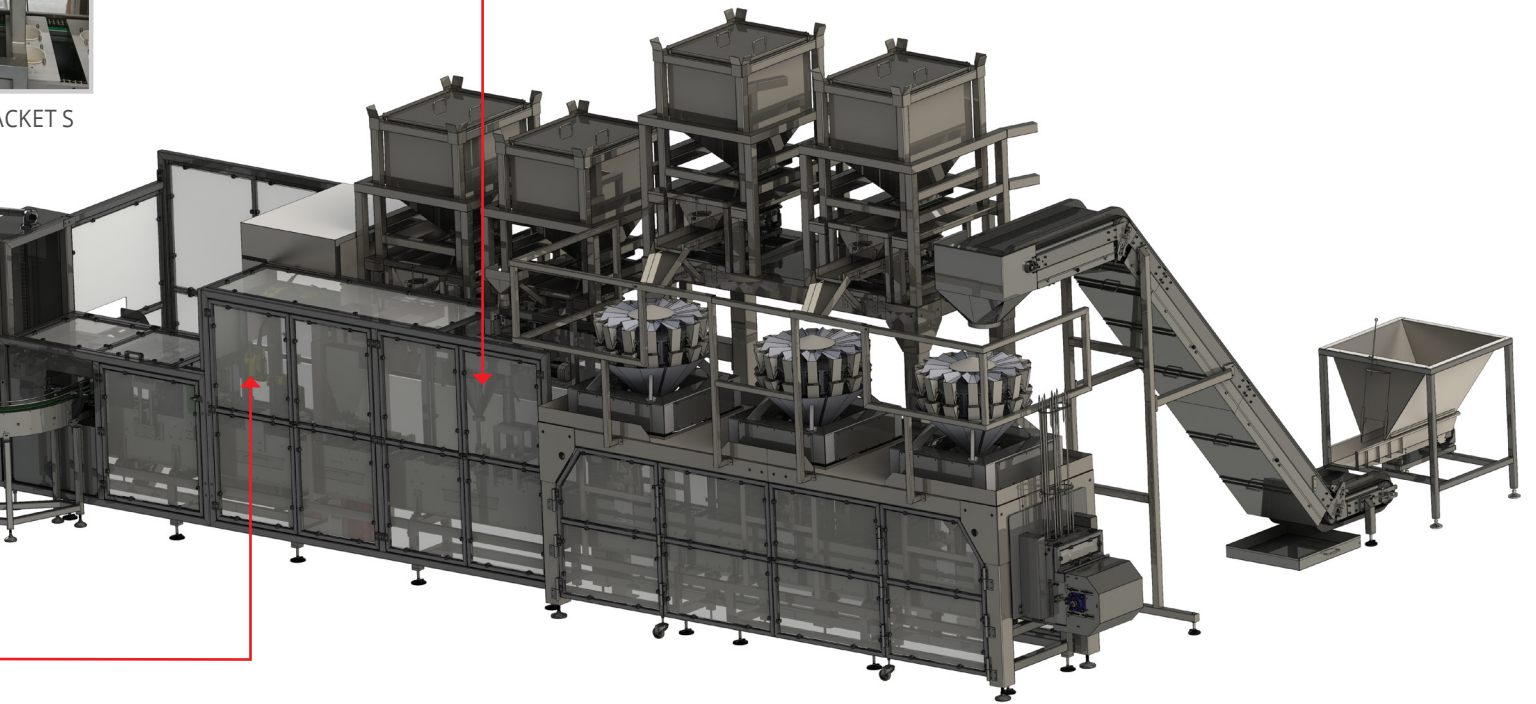

Rotating table OS

# LUNA-T | LUNA-L



## TUBE AND CUP FILLING LUNA-T | TUBE AND CUP CLOSING LUNA-L

The shown line includes: depalletizing equipment | conveyor system for the supply and removal of empty and full packages | filling station LUNA-T | lid applicator LUNA-L with lid storage hopper and lid conveyor | multihead weighers CHW210 | rotating table OS | big bag station | checkweighers with metal detector | marking device

Output: up to 45 packages/min.\*

Device dimensions: LUNA-T w 1500 mm | d 1000 mm | h 2050 mm without dosing device  
LUNA-L w 2300 mm | d 1300 mm | h 2100 mm

Package dimensions: ø 70-120 mm | h 80-300 mm | individual request | multiple formats

Package material: paper | plastic | glass

Closing: lid - lid applicator LUNA-L | BLEMA | STILLER

Lid types: plastic, non-screw, with tear-off strip Easy Lock, Snap-On

Packed products: loose (powders, granules) | small pieces



Filling station LUNA-T



Lid applicator LUNA-L

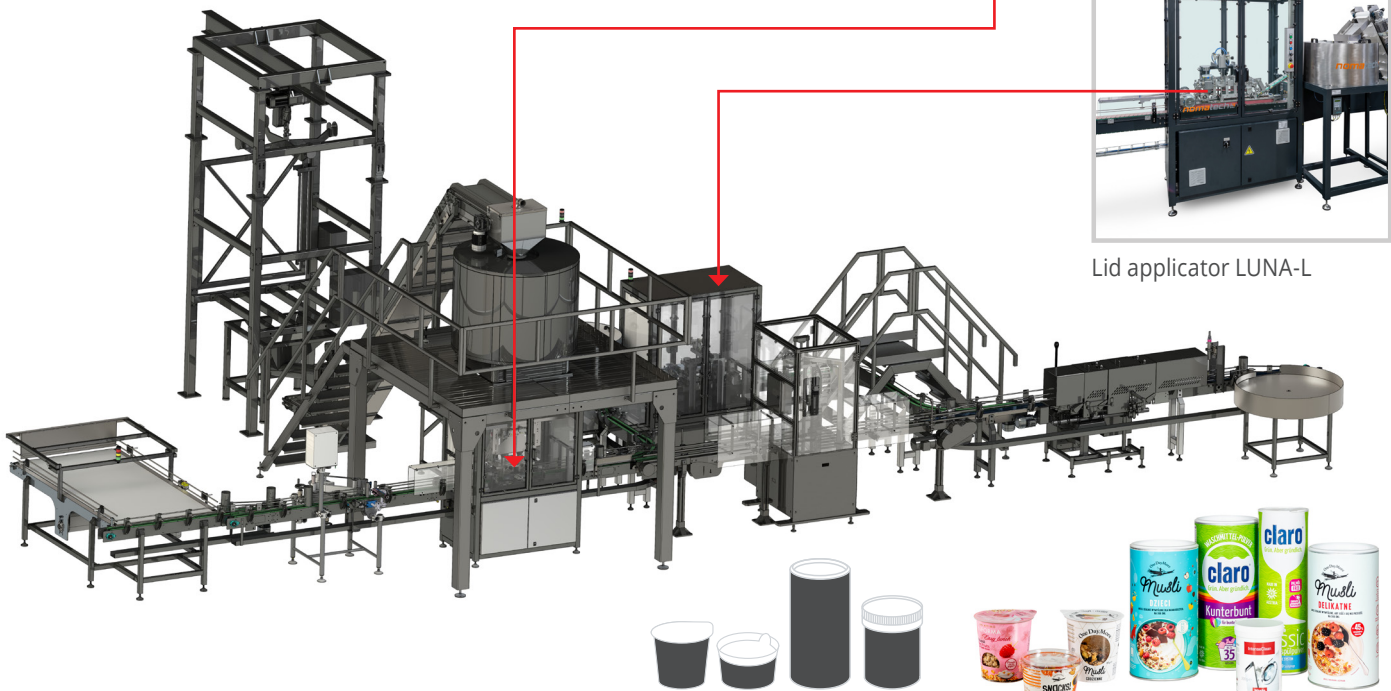

\*depending on the filled amount, product type and package dimensions

Note: All complete lines are always designed individually depending on the customer's requirements.

## OUR MANUFACTURE PROGRAM:

**TOBOGAN** Vertical packaging machines  
**VOLCANO** Multilane stickpack packaging machines  
**GOLEM** Bulk bags packaging machines  
**BOX** Cartoning machines

**CUBE** Brickpack packaging lines  
**CASE** Group packaging casepackers  
**ROBO** Manipulation lines, palletization  
**LUNA** Filling and mixing lines  
Wide range of accessories and more.



NOMATECH s.r.o.  
info@nomatech.net | www.nomatech.net | +420 317 843 235  
Vlasákova 1635 | 258 01 Vlašim | Czech Republic  
Tradition since 1965



Co-funded by  
the European Union

**nomatech**  
YOUR PACKAGING MACHINES